

GEOLOGY OF KOH-I-SUFAID MOUNTAIN, NORTH OF PARACHINAR AND ITS CORRELATION WITH OTHER AREAS OF COMPARABLE GEOLOGY AND MINERALIZATION

K.A. BUTT

Hardrock Division, Atomic Energy Minerals Centre,
P.O. Box No. 734 (University), Peshawar

ABSTRACT

Geology of Koh-i-Sufaid imbricate zone, North of Parachinar is described and compared with similar occurrences in Thakot-Besham and Nanga Parbat-Haramosh area. Ductile deformation exposed in the migmatitic rocks of these areas is interpreted to be due to structurally up thrown block of deep seated rocks along the older strike slip faults which have developed a significant vertical component during their re-activation under the influence of Himalayan orogeny.

INTRODUCTION

The curvatures of the mountain belts in Pakistan have been a subject of several studies. Sarwar and DeJong (1979) discussed a number of such curvatures. Hazara-Kashmir syntaxis was described by Wadia (1931), Calkin et al. (1975), Desio (1976), Gansser (1964) and Crawford (1974), and Nanga Parbat-Haramosh massif by Desio (1976, 1979). More recently Bossart et al. (1984) have given a new structural interpretation of the Hazara syntaxis.

This study deals with three major loop-like structures associated with the Main Mantle Thrust (MMT) (Fig. 1).

- i) Nanga Parbat-Haramosh massif.
- ii) Thakot-Besham migmatite zone.
- iii) Parachinar imbricate thrust zone.

Nanga Parbat-Haramosh massif forms the most prominent loop in the MMT, which separates the Indo-Pak plate sequences from the Kohistan Island arc. The geology of the area was first described by Misch (1949). Metasomatic granitization of batholithic dimensions was the interpretation put forth by Misch (1949). Considering the geology, metamorphism and magmatism in the area, it can also be interpreted as an insitu anatectic migmatitic complex.

Butt (1983) described a migmatitic complex from Thakot-Besham area and its associated lead, zinc, tungsten, molybdenum and uranium mineralization. This complex is also located in a curvature in the MMT, hereinafter referred as Thakot re-entrant.

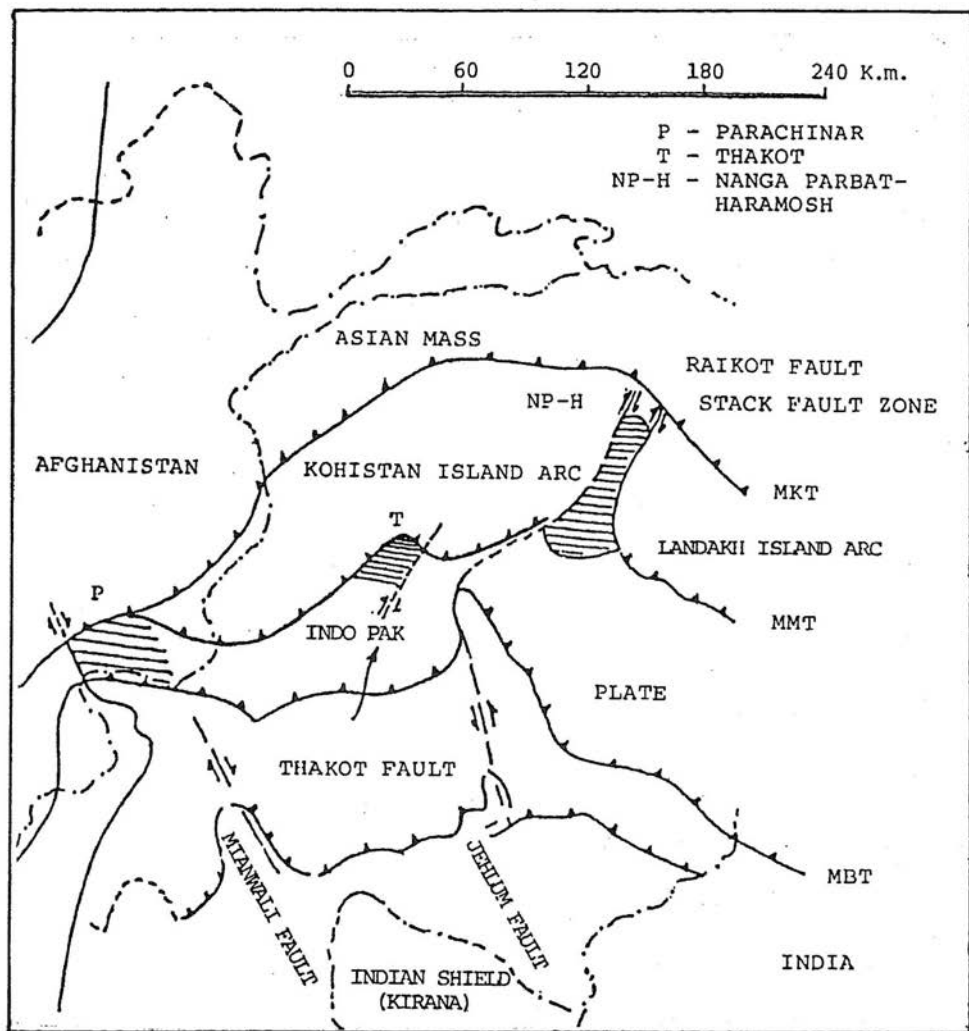

Fig. 1. Generalized tectonic map of Pakistan showing position of migmatite complexes.

This paper reports slices of migmatitic rocks exposed in an imbricate thrust zone in Koh-i-Sufaid area North of Parachinar. This area is, hereinafter, referred as Parachinar re-entrant.

GEOLOGY OF PARACHINAR RE-ENTRANT

Regional geology of Parachinar area was published by Meissner et al. (1975). The stratigraphic succession in Parachinar area established by them is following:

	Mafic Igneous rocks
Cretaceous	Kurram Formation
	Lumshiwai Formation
	Chichali Formation

Quartzites
 UNCONFORMITY
 Samana Suk Formation
 Datta Formation
 Jurassic
 Jurassic rocks (Undifferentiated)

Northern most part of the area was mapped by Meissiner et al. (1975) and has quartzites of Cretaceous age. A geological map of the area has been prepared by FATA Development Corporation with description of what was termed as "Igno-metamorphic zone" (Badshah, 1983).

Across the border, in Afghanistan, this zone favourably correlates with the Himalayan crystalline Schoepfen zone (Shroeder, 1984). Metamorphic and igneous rocks of this zone are thrust on to unmetamorphosed Jurassic and Cretaceous sediments (Fig. 2).

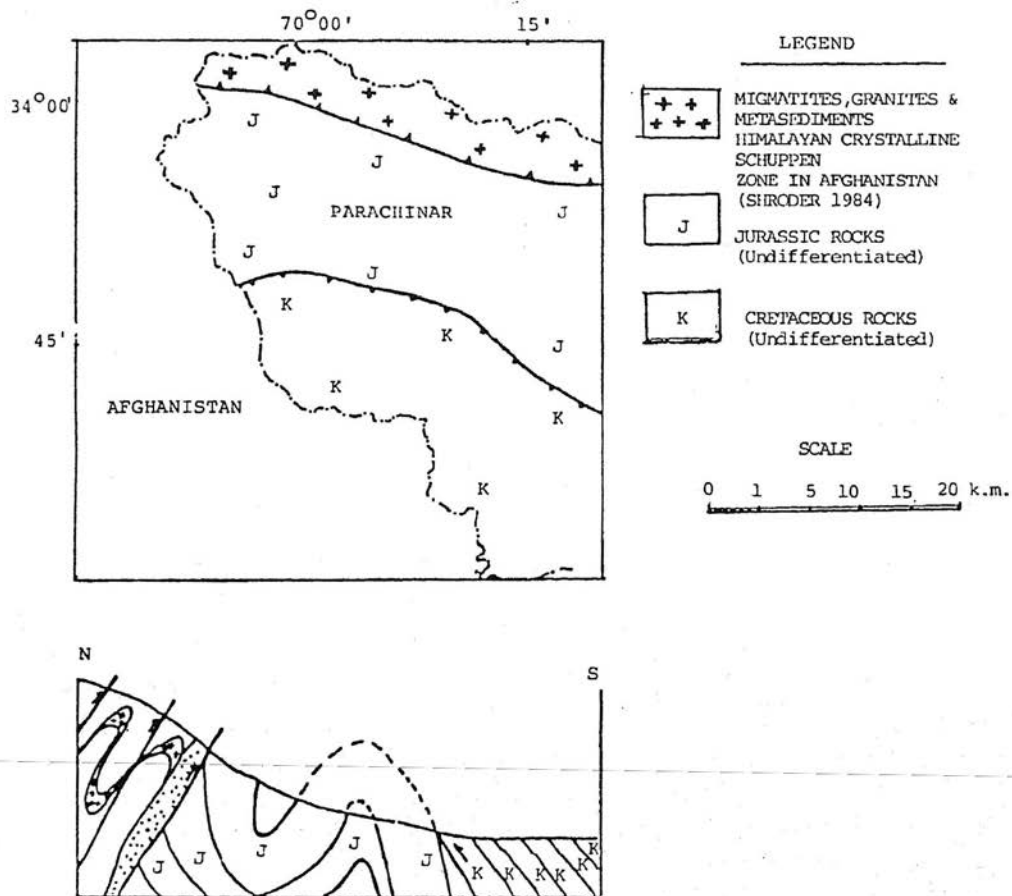

Fig. 2. A. Regional geological map of Parachinar area.
 B. Geological cross section along eastern margin of map.

Structure of Imbricate Zone North of Parachinar:

NW-SE trending and north dipping high angle reverse faults separate various rock units in the area. The adjoining fault blocks show extreme variation in metamorphism from augen gneisses, migmatitic blocks with ductile deformation to amphibolites, schists, phyllites and dolomites. This zone is, therefore, interpreted as an imbricate fault zone involving basement migmatites as well as unmetamorphosed Jurassic and Cretaceous. Sedimentary rock. Slices of migmatized basement are tectonically emplaced and show different degrees of cataclastic deformation ranging from augen gneisses to mylonites and ultra mylonites.

The base of this zone is represented by a major thrust which is probably structurally equivalent to the Panjal Thrust (Butt, in preparation).

Igneous and metamorphic components of the Koh-i-Sufaid imbricate zone is reminiscent of migmatites of the Besham Group (Butt, 1983; Baig and Lawrance, 1987) exposed along Thakot Fault as well as parts of Nanga Parbat-Haramosh massif (Misch, 1949). Some of the significant geological characteristics of the Parachinar re-entrant are summarized as follows:

1. Imbricate thrust zone in Koh-i-Sufaid area involved lithologies ranging from migmatites to granitic gneisses with varying degree of cataclasis. Also included are low grade metamorphic rocks possibly correlative of Precambrian sequences of Indo-Pak plate. These rocks are thrust on Jurassic and Cretaceous strata.
2. Blocks containing migmatized metamorphic rocks show abundant evidence of ductile deformation which predates the cataclastic event, possibly associated with younger thrusting.
3. A late stage primary uranium mineralization (Baig, 1976; Rehman and Jaseem, 1978) is associated with the pegmatites associated with plastically folded migmatitic granites.
4. These pegmatites are simple, with quartz, feldspar and mica as major minerals. Some of the pegmatites are suspected to have tourmaline.
5. Parachinar re-entrant is a rather gentle flexure in MMT (Fig. 2) but its western extremity is truncated by a strike slip fault (Desio, 1979).
6. Age of migmatites is not certain but considering the similarity of lithological and other geological features with comparable area, they are tentatively assigned a Precambrian age.
7. Abundant talc-magnesite mineralization is characteristic of the Parachinar re-entrant.
8. A block diagram showing the proposed structure of the Parachinar re-entrant is given in Fig. 3.

THAKOT RE-ENTRANT

Butt (1983) described Thakot re-entrant to contain migmatite rocks and associated Lahor complex (Fig. 1). These rocks provide evidence that an insitu melting was, probably, responsible for the formation of pegmatoids and Lahor granite exposed in Thakot re-entrant. Following geological features about this area are characteristic:

1. Lithology comprising of granites, pegmatoids and metamorphic rocks with pelitic, calcareous and carbonaceous components.

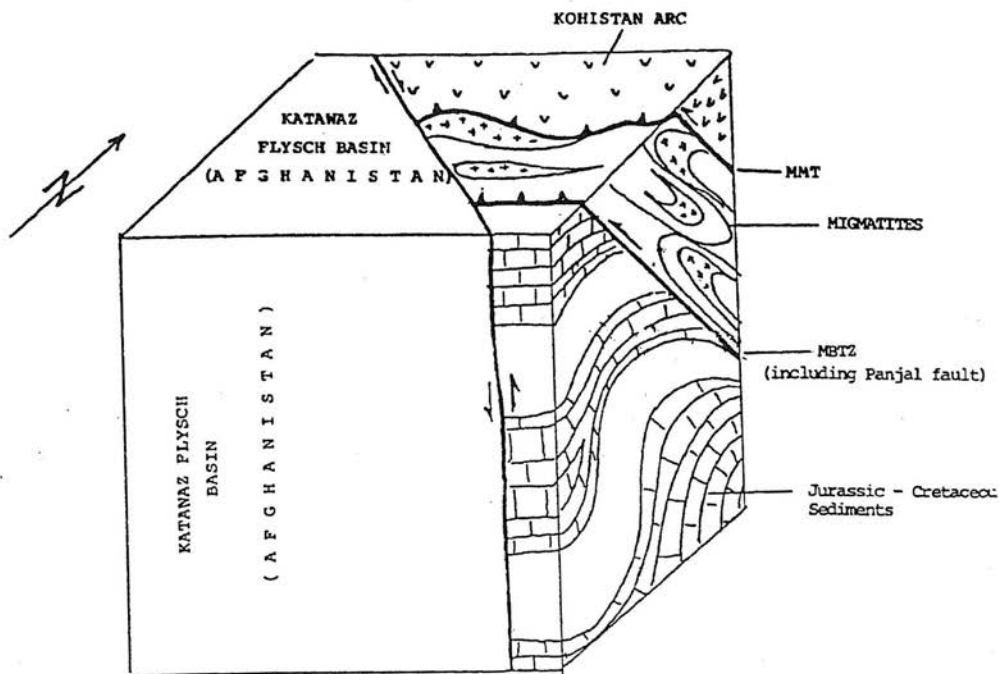

Fig. 3. Block diagram of the proposed structure of Parachinar re-entrant.

2. Abundant development of calc-silicates as in Lahor, Besham and Dobair area.
3. Abundance of ductile deformation in migmatitic and granitic portions of the rocks.
4. A late stage uranium, molybdenum, lead, zinc mineralization, spatially and possibly genetically, related to pegmatites and granites.
5. Pegmatites are simple; quartz, feldspar, mica and sometimes tourmaline are the major constituents.
6. Close association with a strike slip fault (Thakot Fault) and the exposure of migmatites within a re-entrant of MMT.
7. Age of the Besham Group is interpreted to be proterozoic (Butt, 1983; Baig and Lawrance, 1987).
8. Talc-magnesite association in the metamorphic complex is characteristic.
9. A block diagram showing the proposed structure of Thakot re-entrant is shown in Fig. 4.

NANGA PARBAT HARAMOSH MASSIF

Misch (1949) produced geological evidence which led to the conclusion that metamorphism and granitization (possibly anatectic melting, considering magmatic view) are a function of increasing temperature towards the core of the massif. Following geological characteristics of this area are taken from Misch (1949):

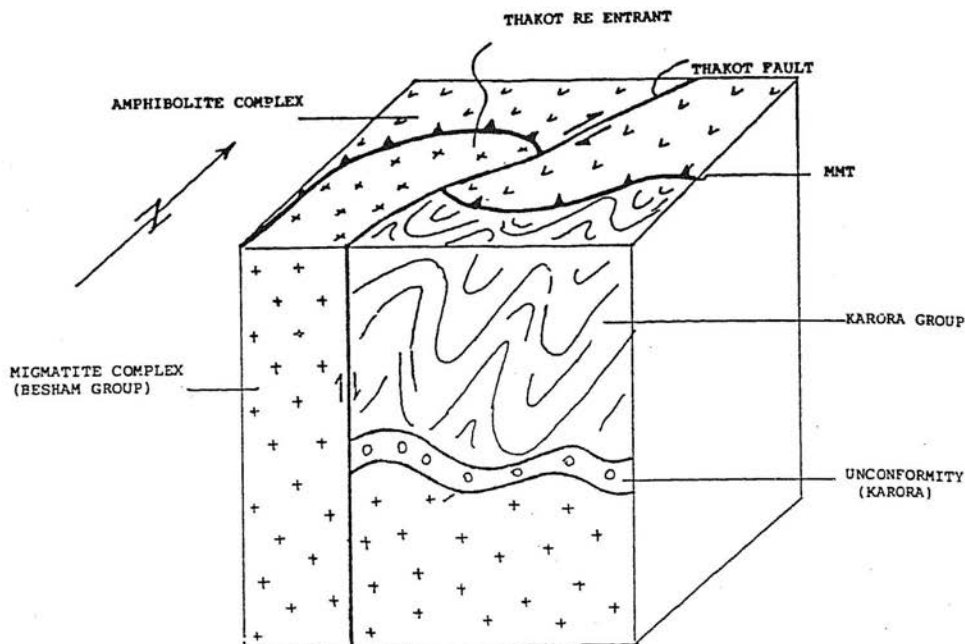

Fig. 4. Block diagram of the proposed structure of Thakot re-entrant.

1. Lithology comprising of granites, pegmatites and metamorphic rocks with pelitic, calcareous and carbonaceous components.
2. Abundant development of calc-silicates.
3. Abundant ductile deformation in older pegmatites/migmatites.
4. Late stage accumulation of uranium in mariolitic cavities (unpublish. data, this author). Both simple and complex pegmatites are known from the massif.
5. A close association with Riakot Fault and Stak Fault zone (Baig and Lawrance, 1987) and its location in a loop in MMT.
6. Age is reported to be 2.2 b.y. (Zietler et al., in press).
7. Talc-megnesite association in the metamorphic complex.
8. A block diagram for the proposed structure of NP-H massif is presented in Fig. 5.

This author considers the gneiss and migmatites of the Koh-i-Sufaid imbricate zone appear to be equivalent of the Besham Group as well as migmatites of the Nanga Parbat-Haramosh massif and represent basement of the Indo-Pak plate. Granitic rocks, pegmatites and migmatitic parts of these areas host uranium mineralization of identical geological and mineralogical characteristics (Table 1).

These three migmatitic areas are basement blocks exposed possibly due to upthrusting along the basement faults reactivated during Himalayan orogeny (Baig and Lawrance, 1987).

TABLE 1. COMPARISON OF URANIUM MINERALIZATION IN KOH-I-SUFAID IMBRICATE ZONE IN PARACHINAR, THAKOT AND NP-H MASSIF

Parachinar	Thakot	NP-H massif
<i>Host Rock:</i>		
Pegmatitic and migmatitic rocks with both granitic and metamorphic components. Pegmatites and granites are simple with abundant tourmaline. Sulphide minerals associated. Granitic rock non-porphyrific.	Pegmatoid rocks and associated migmatites with both granitic and metamorphic components. Pegmatites are quartzo feldspathic with rare biotite. Granitic rocks are non-porphyrific. Abundant associated calc-silicates.	Pegmatites, granites and associated metasediments. Pegmatites are complex and contain topaz, fluorite, beryl and garnet. Calc-silicates common. Simple pegmatites also present.
<i>Structure:</i>		
Plastic deformation both in pegmatites and migmatites. Other metamorphics and sediments involved in the imbricate zone show brittle deformation.	Abundant ductile deformation features.	Abundant ductile deformation features in the older granitic gneiss and pegmatites.
<i>Uranium Mineralization:</i>		
Two types of mineralization has been encountered:	Two types of mineralization has been encountered:	Two types of mineralization has been encountered:
<ol style="list-style-type: none"> 1. Spotty uraninite crystals in mariolitic cavities in granites and pegmatite. 2. Fracture filling uraninite and base metal sulphids mineralization. 	<ol style="list-style-type: none"> 1. Spotty uraninite in mariolitic cavities in granite near Besham and Jabbagai. 2. Fracture filling mineralization, containing uraninite, molybdenite galena, pyrite, pyrrhotite and sphalerite. 	<ol style="list-style-type: none"> 1. Diseminated uraninite in granitic and pegmatitic rocks as well as in the mariolitic cavities therein. 2. Fracture filling type of veins showing distinct haematite staining associated with sulphide minerals.
<i>Tectonic Position:</i>		
Located in re-entrant. Parachinar imbricate zone is truncated by MMT in the north and a strike slip fault in the west (Desio, 1979).	Located in Thakot re-entrant. Thakot fault is a strike slip fault possibly in the basement (Baig and Lawrance, 1987) re-activated during younger orogeny.	Located in NP-H loop, a major re-entrant in MMT. Nanga Parbat Haramosh loop is also bounded on both sides by two faults which have a dominant strike slip component of movement.

The present display of basement rocks at Nanga Parbat-Haramosh massif, Koh-i-Sufaid, Parachinar and Thakot is due to their being structurally upthrown blocks along the strike slip faults which may have developed some vertical component of movement as well. This would explain their occurrence in an otherwise generally low grade metamorphic domains of the Indo-Pak plate.

PRE-HIMALAYAN FOLDING

Most prominent structural features of the geology of north Pakistan is a generally East-West strike direction except in the close vicinity of syntaxes or re-entrants. Another significant

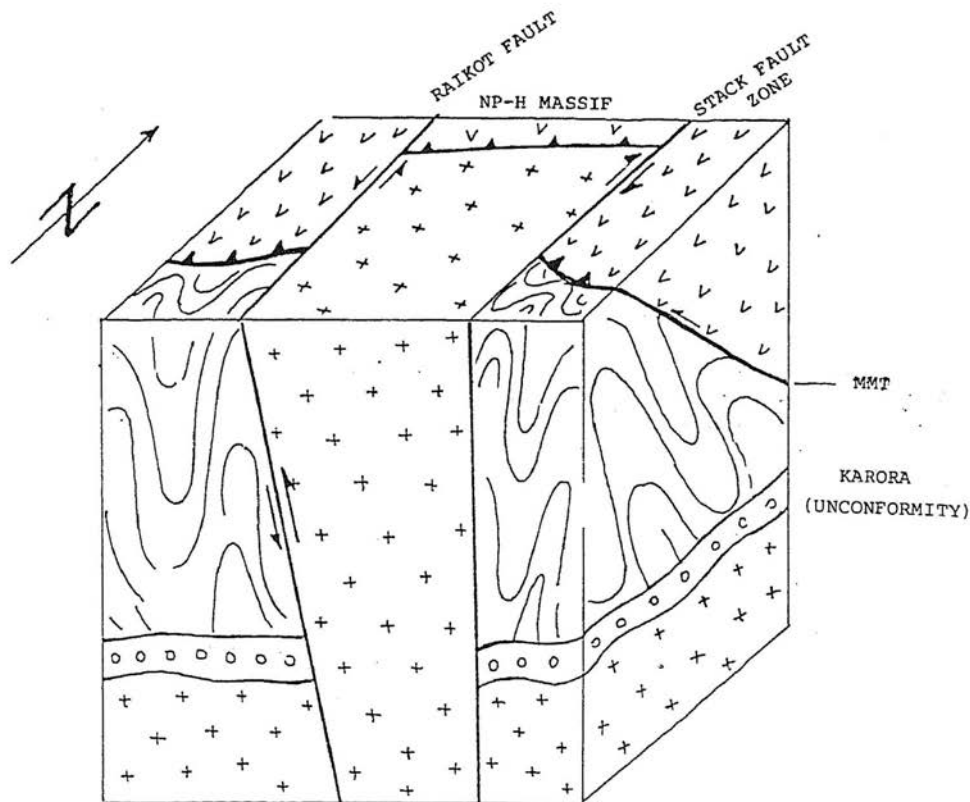

Fig. 5. Block diagram of the proposed structure of NP-H massif.

feature is several north dipping thrust faults which are considered responsible for the southward mass transport. Greco (1986) investigated a part of section from Lamian to Reshian in Azad Kashmir. The upper reaches of the section include "Salkhala Formation" of Precambrian age and structurally emplaced slices of gneissic granitic rocks of possible proterozoic age. Therefore he concluded that the thrusts responsible for north west to southeast mass transport are Himalayan and the dominant cleavage observed in Lamnian-Reshian section is due to thrusting.

The development of cleavage due to thrusting in the immediate vicinity of the thrust zone is understandable but the widespread occurrence of a penetrative cleavage in various formations throughout the section can not be explained by thrusting alone. A tight isoclinal folding, with fold axis trending NW-SE and dipping north, is observed in the area. A new structural interpretation of Reshian-Lamnian section is given in Fig. 6. This section portrays the nature of folding in Precambrian-Palaeozoic strata of the Indo-Pak plate. This folding event is related to the Himalayan orogeny which, eventually, lead to brittle failure producing thrusts and Nappe structures and caused a SE mass transport. Fig. 7 shows the fold types related to Himalayan deformation.

Within these folded structure, however, one can observe older cylindrical folds which, though have the axial plans practically parallel to the younger event, yet their shapes and

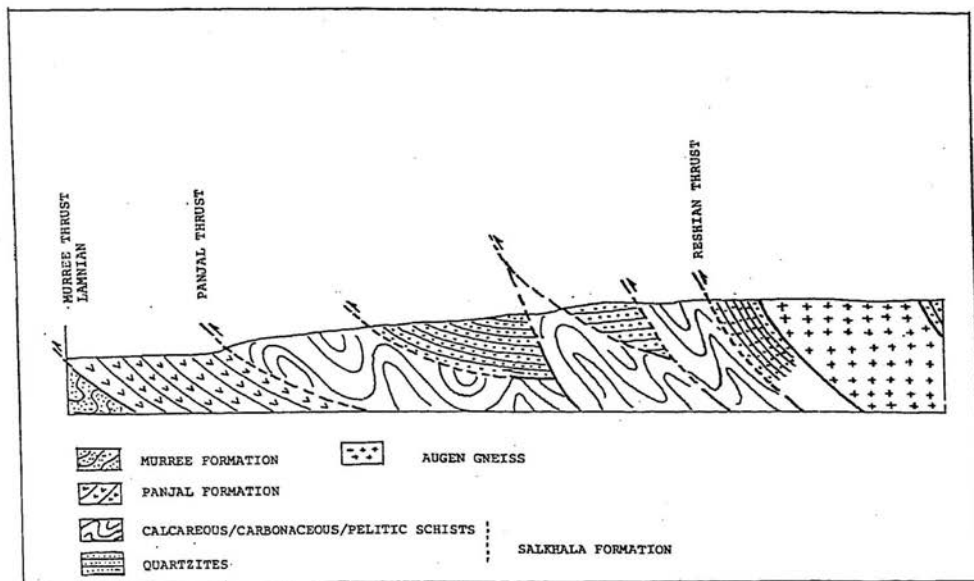

Fig. 6. Structural interpretation of geological section along Reshian-Lammian road (Azad Kashmir) from G.R. 760212 to G.R. 870291.

orientation in space is entirely different (Fig. 8). Relationship between the two folding events, as observed in the field, is diagrammatically shown in Fig. 9. In order for these rocks to be subject to such folding events the following steps are envisaged:

Considering the F2 folding (Himalayan), wherein primary stress direction is NNW, this would result in a primary fold direction of ENE/E-WSW/W. The strike of thrusts related to this phase of folding will also be the same. The strike slip fault will have a strike of NS ($N9^{\circ}E$) or EW ($N52^{\circ}W$) (Fig. 10).

The interpretation of F1 folding and its associated faults in terms of major stress direction is difficult. It is assumed that the stress developed in the orogens is an essentially horizontal stress field. When translated in to such a horizontal stress field, the major stress direction of F1 folds comes out to be approximately ENE (Fig. 11). Major fold and thrust direction is NNW-SSW. Strike slip faults related to such folding event would be NE ($N37^{\circ}E$) or EW ($N82^{\circ}W$) (Fig. 11).

Strike slip faults displacing MMT i.e. Thakot Fault, Raikot Fault and Stak Fault (Fig. 1), have a generally $N30^{\circ}E$ trend. This trend can be correlated to one of the strike slip direction of F1 folding event where the second possible direction would be practically indistinguishable from the predominant E-W thrust direction. Strike slip fault direction possibly related to F2 event ($N52^{\circ}W$) where $N10^{\circ}E$ does not have any distinct representation and was possibly not developed. The above vectorial analyses is in agreement with the earlier workers. Swaminath et al. (1964) concluded that the re-entrants correlate with strike slip faulting of the basement. F1 folding event and its reactivation during the F2 event is responsible for re-entrants in MMT, while F2 event is solely responsible for re-entrants in Main Baundany Thrust and Salt Range.

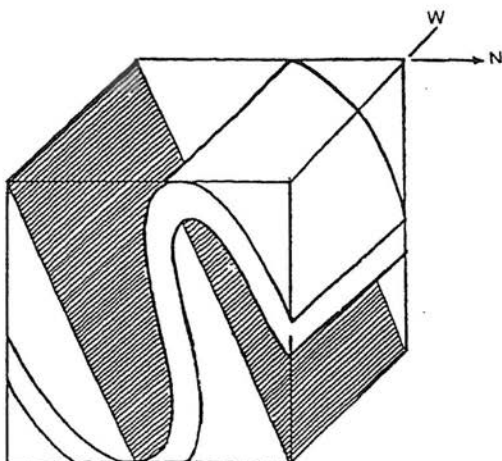

Fig. 7. Isoclinal F2 folding in Reshian area (Azad Kashmir).

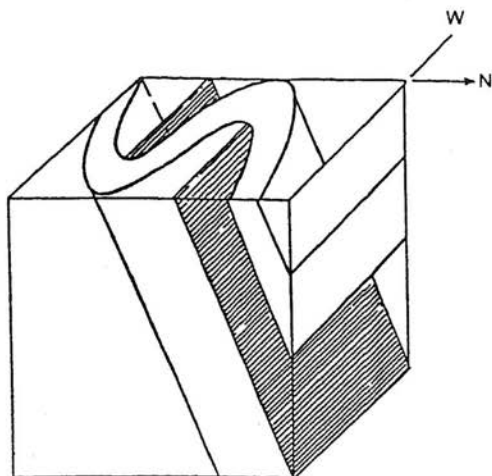

Fig. 8. Cylindrical F1 folding in Reshian area (Azad Kashmir).

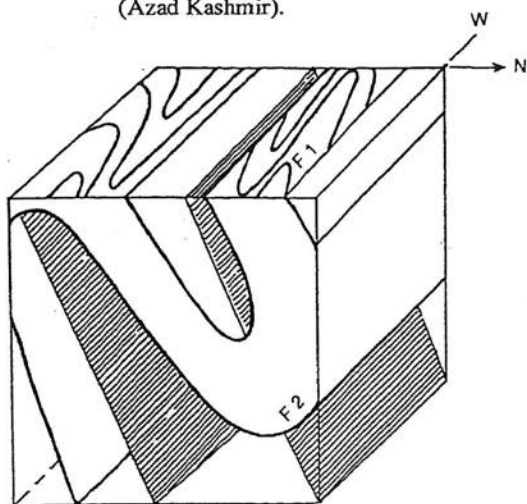

Fig. 9. Relationship between F1 and F2 folding in Reshian area (Azad Kashmir).

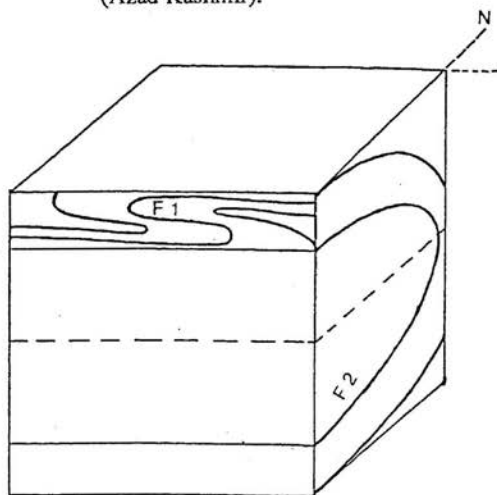

Fig. 10. F1 and F2 folding in Precambrian granite gneiss on Chattar-Battagram road, District Manshara.

Naha and Ray (1970, 1971) have worked out similar two phases of deformation for stratigraphically comparable rocks in Simla hills. Similar two phases of folding are also shown by the gneissic rocks on Chattar-Battagram Road (Fig. 12). This road section displays a practically flat lying cleavage in granite gneiss of possibly Cambrian or Precambrian age. The dominant cleavage in the gneiss is axial planner to F2 folding while the older cleavage produced during F1 folding event is practically sub-parallel to that produced during F2 event.

It is therefore concluded that the deformation history of the rocks east of Hazara-Kashmir syntaxis (this study) and further east in Simla hill (Naha and Ray, 1970, 1971) are comparable to Hazara area west of the syntaxis.

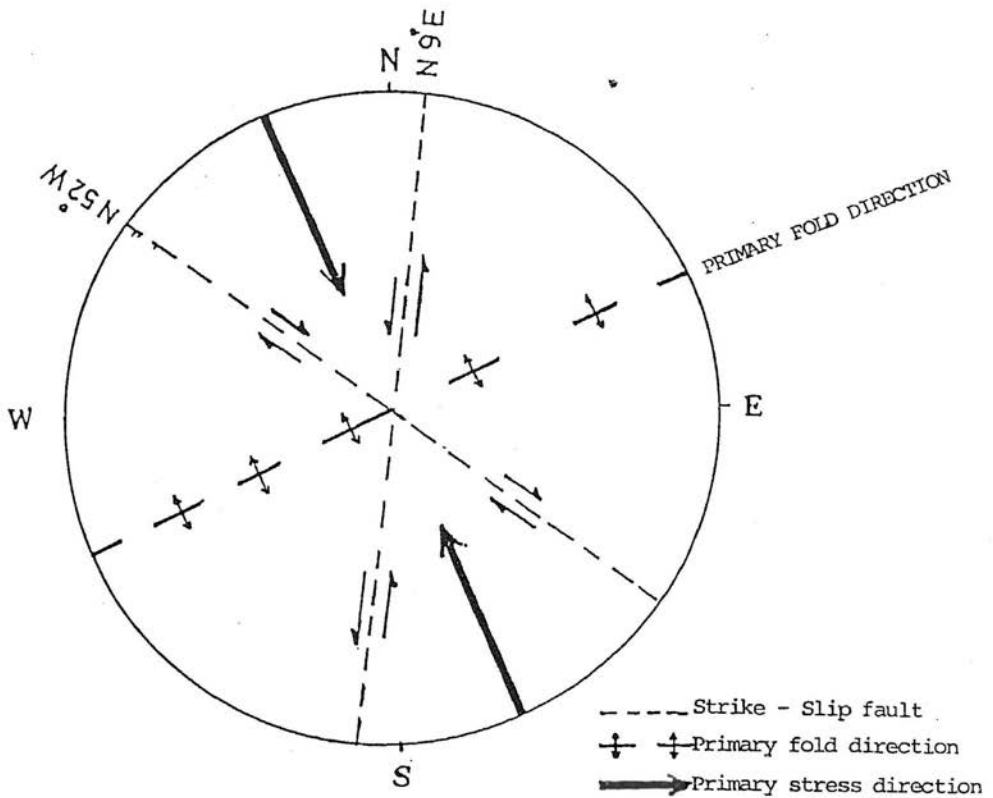

Fig. 11. Possible strike slip faults developed during F2 folding event in the Precambrian rocks of north Pakistan (after Moody and Hill, 1956).

The existence of anatectic migmatites and associated high grade metamorphic rocks, in close spatial association of strike slip faults, also suggest that the Himalayan reactivation may have produced a significant component of vertical movement on these faults. Such a movement could have up thrown deep seated anatectic migmatites against generally low grade metamorphic rock of the Indo-Pak plate.

IMPLICATION ON MINERAL EXPLORATION STRATEGY

Sillitoe (1979) speculated that Himalayas are inherently poor in post-Palaeozoic mineralization. He also suggested that pre-Mesozoic ore types could hold the best potential in the Himalaya which were later subjected to Himalayan orogeny. Uranium mineralization associated with re-entrants at Parachinar, Thakot and NP-H massif and their close spatial association with reactivated basement faults may be a significant characteristic which renders these areas favourable for intensive mineral search programmes. Similarly the distinction between the older structure and the ones reactivated during Himalayan orogeny, and the structure produced during Himalayan orogeny will make a focal point in any mineral exploration programme in Indo-Pak plate in north Pakistan.

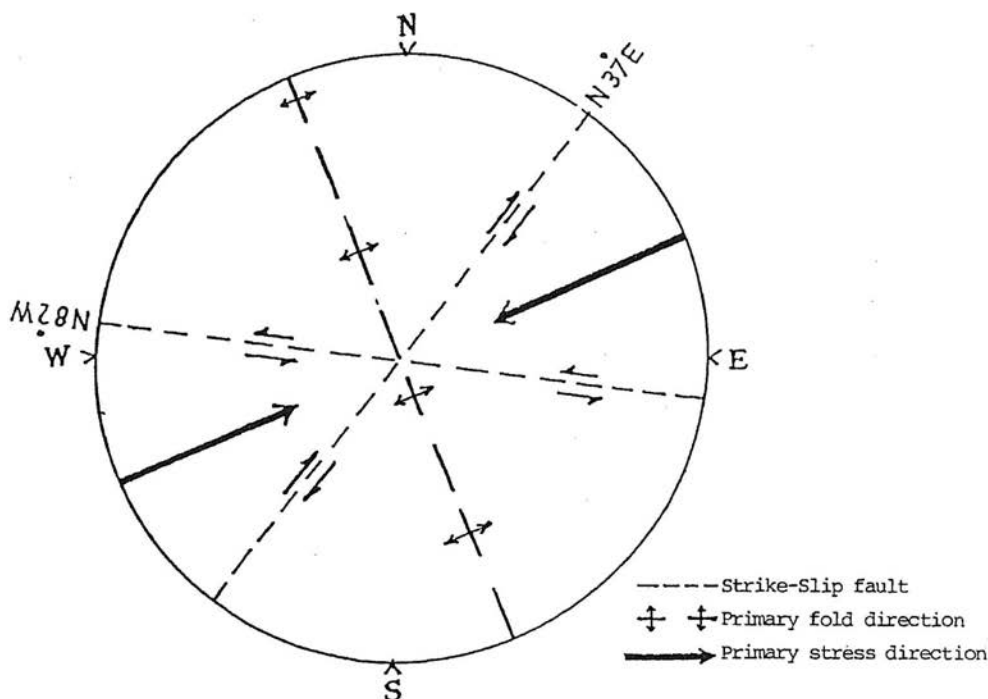

Fig. 12. Possible strike slip faults developed during F1 folding event in the Precambrian rocks of north Pakistan (after Moody and Hill, 1956).

REFERENCES

- Badshah, M.S., 1983. Soapstone deposits of Daradar Valley, Kurram Agency. Proc. 2nd National Seminar on development of Mineral resources. Baig, S.M.A., 1976. Preliminary report on Radioactive occurrences in Parachinar. Unpublished Report AEMC, Lahore.
- Baig, M.S. & Lawrance, R.D., 1987. Precambrian to early Paleozoic orogenesis in the Himalaya. *Kashmir Jour. Geol.* 5, 1-22.
- Bossart, P., Dietrich, D., Greco, A., Ottiger, R. & Ramsay, J.G., 1984. A new structural interpretation of the Hazara Kashmir syntaxis southern Himalaya, Pakistan. *Kashmir Jour. Geol.* 2, 19-36.
- Butt, K.A., 1983. Petrology and geochemical evolution of Lahor pegmatoid/granite complex, north Pakistan, and gneisses of associated Pb-Zn, Mo & U mineralization. In: *Granites of Himalayan, Karakoram & Hindu-Kush* (F.A. Shams, ed.) Inst. of Geol. Punjab Univ. Lahore Pakistan 309-326.
- Calkins, J.A., Offield T.W., Abdullah, S.K.M. & Ali, S.T., 1975. Geology of the southern Himalaya in Hazara Pakistan and adjacent areas. U.S. Prof. Paper 716-C, 29p.
- Crawford, A.R., 1974. The Salt Range, the Kashmir syntaxis and the Pamir arc. *Earth and Planet. Sci. Letters* 22, 371-379.
- Desio, A., 1979. Geologic evolution of the Karakoram. In: *Geodynamics of Pakistan* (A. Farah & K.A. De Jong, eds.) *Geol. Surv. Pakistan, Quetta* 111-124.
- Desio, A., 1976. Some geotectonic problems of the Kashmir Himalaya-Kashmir-Hindu Kush-Pamir, *Atti dei convegni Lincei* 21, 115-125.

- Gansser, A., 1964. *Geology of Himalayas*. Interscience London, 289 p.
- Greco, A., 1986. Geological investigation in the Reshian area (Jhelum Valley, Azad Kashmir). *Kashmir Jour. Geol.* 4, 51-66.
- Meissner, C.R., Hassain, M., Rashid, M.A. & Sethi, U.B., 1975. *Geology of Parachinar quadrangle, Pakistan*. U.S.G.S. Prof. Paper 716-6., 20 p.
- Misch, P., 1949. Metasomatic granitization of batholithic dimension. *Amer. J. Sci.* 274, 209-254.
- Moody, J.A. & Hill, M.J., 1956. Wrench-fault tectonics. *Geol. Soc. Amer., Bull.* 67, 1207-1248.
- Naha, K., & Ray, S.K., 1970. Metamorphic history of the Jatogh Series in Simla Klippe, Lower Himalaya Cont. *Min. Pet.* 28, 147-164.
- Naha, K. & Ray, S.K., 1971. Evidence of overthrusting in the metamorphic terrain of Simla Himalaya. *Amer. Jour. Sci.* 270, 30-42.
- Rehman, M.A. & Jaseem-ud-Din, S., 1978. Nature of Uranium Thorium mineralization in Parachinar area, N.W.F.P., Pakistan. Unpublished report AEMC/Geo-13 AEMC Lahore.
- Sarwar, G. & DeJong K.A., 1979. Arcs, oroclines, syntaxes. The curvatures of mountain belts in Pakistan. In: *Geodynamics of Pakistan* (A. Farah & K.A. DeJong, eds), *Geol. Surv. Pakistan Quetta*, 341-349.
- Shroeder, J.F., 1984. Comparison of tectonic and metallogenic provinces of Afghanistan to Pakistan. *Geol. Bull. Univ. Peshawar*, 17, 87-100.
- Sillitoe, R.H., 1979. Speculation on Himalayan metallogeny based on evidence from Pakistan. In: *Geodynamics of Pakistan* (A. Farah & K.A. De Jong, eds) *Geol. Surv. Pakistan, Quetta* 167-180.
- Swaminath, J., Venkatesh, V. & Sundaram, R.K., 1964. Role of Precambrian lineaments in the evolution of Cenozoic festoons of the Indian subcontinent. *Int. Geol. Congr.*, 22nd, New Delhi, section 11, 316-331.
- Wadia, D.N., 1931. The syntaxis of N.W. Himalayas, its rocks, tectonics and orogeny. *Mem. Geol. Surv. India part 2*.
- Zietler, P.K., Sutter, J.F., Williams, I.S., Zartman, R. & Tahirkheli, R.A.K. in press. Chronology and temperature history of Nanga Parbat Haramosh massif, Pakistan. *Geol. Soc. Amer. Spec. Paper*.